



YLI ELECTRONIC

Mini Electric Bolt for Double Frameless Glass Door

Model: YB-90DU(LED)



Parameters

Face Plate	210Lx34Wx24.5H(mm)
Bolt	10mm DIA, stainless steel 8mm throw
Solid Bolt Holding Force	Polishing stainless steel, bearing 500kg
Signal Output	NC/COM
Time Delay	0/3 sec
Voltage	12 VDC
Stand by	≤ 200mAx2
Current	Start 1200mAx2
Feature	Fail Safe
LED	Light on when locked, light off when unlocked
Suitable for	10-12mm frameless glass door
Induction Distance	8 mm
Face Place Material	High strength aluminum alloy with Japanese crushed grain processing
Weight	0.6 kg

Dimensions

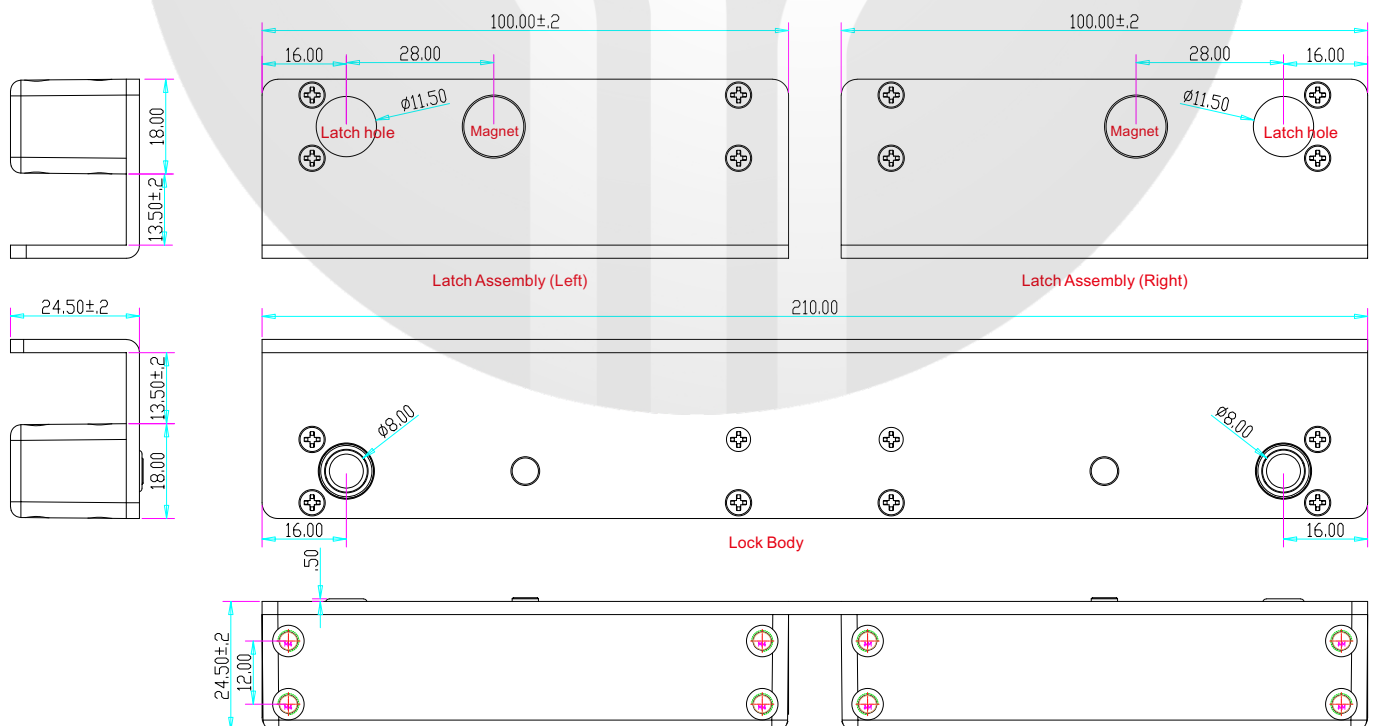

Installation

Steps:

1. Ensure the installation position, clean the glass surface.
2. Fix the spacer inside the U bracket, quantity of spacer can be increased according to the thickness of glass.
3. Paint the glass cement on the internal sideway of the under-part bracket.
4. Screw the bracket by the Allen key.



Attentions:

1. YB-90DU(LED) is specially for the 180 degree in-swing and out-swing frameless glass door.
2. The thickness of glass door is 10-12mm
3. The gap between the down-bracket and electric bolt is : 5-8mm.

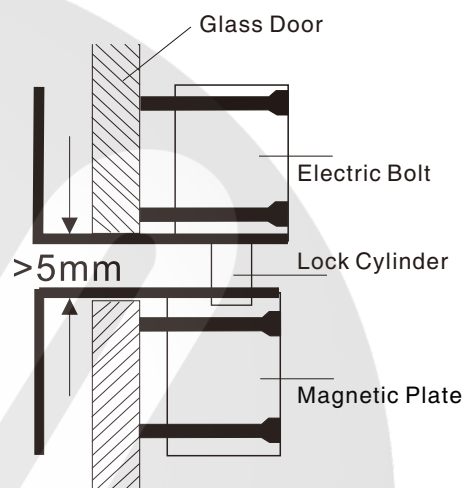

Wiring Diagram

